

2. Phase-Synchronized Oscillator

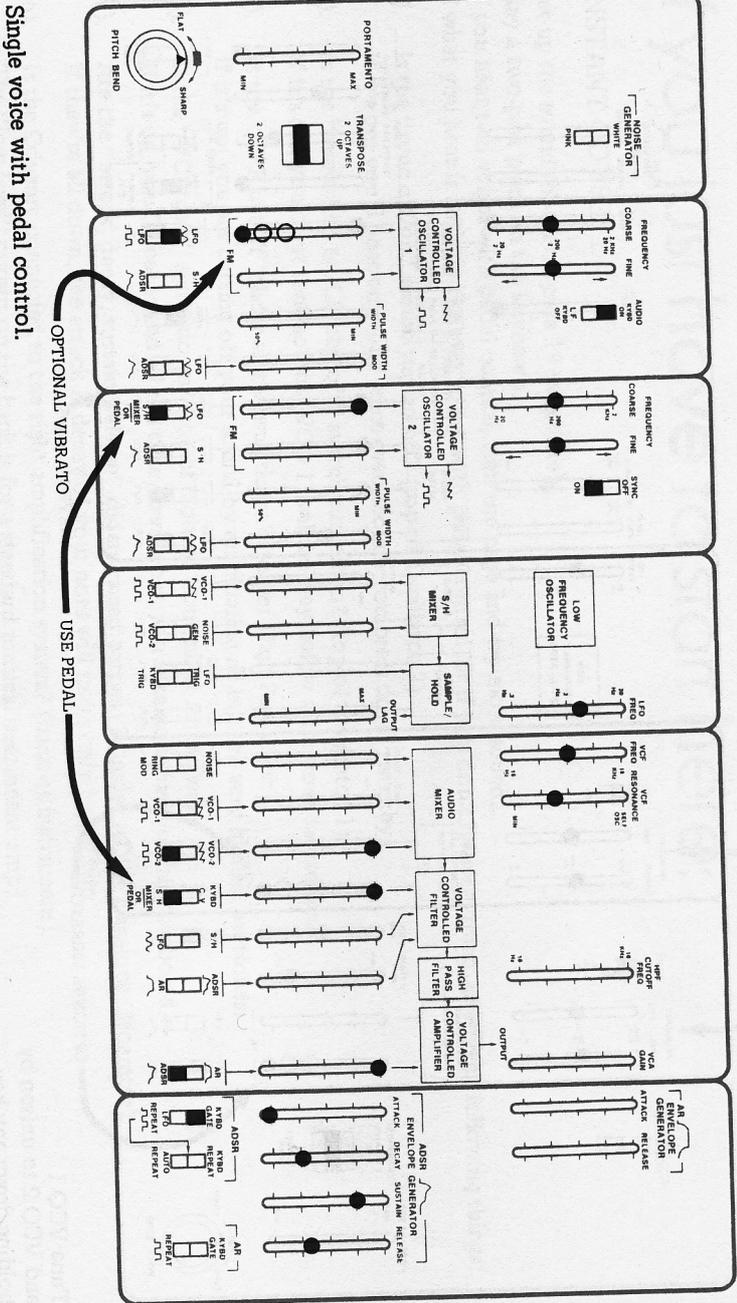

Single voice with pedal control.

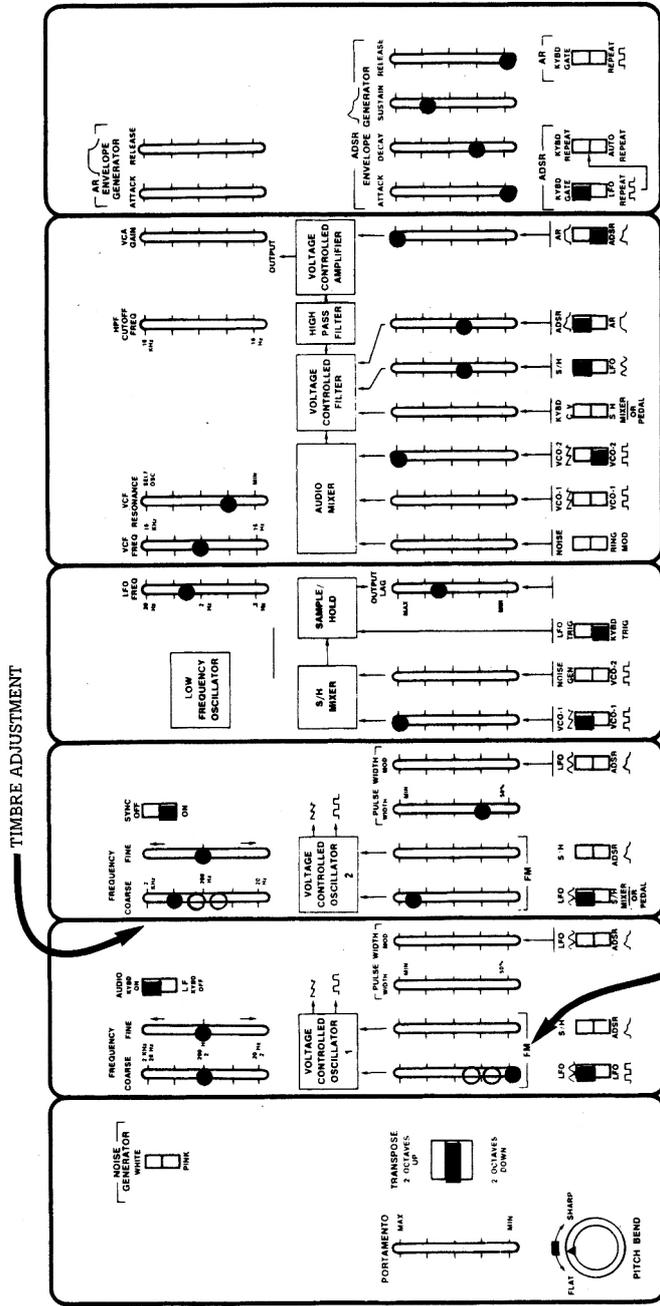

Timbre changes slightly with each note.

3. Guitar-Leslie

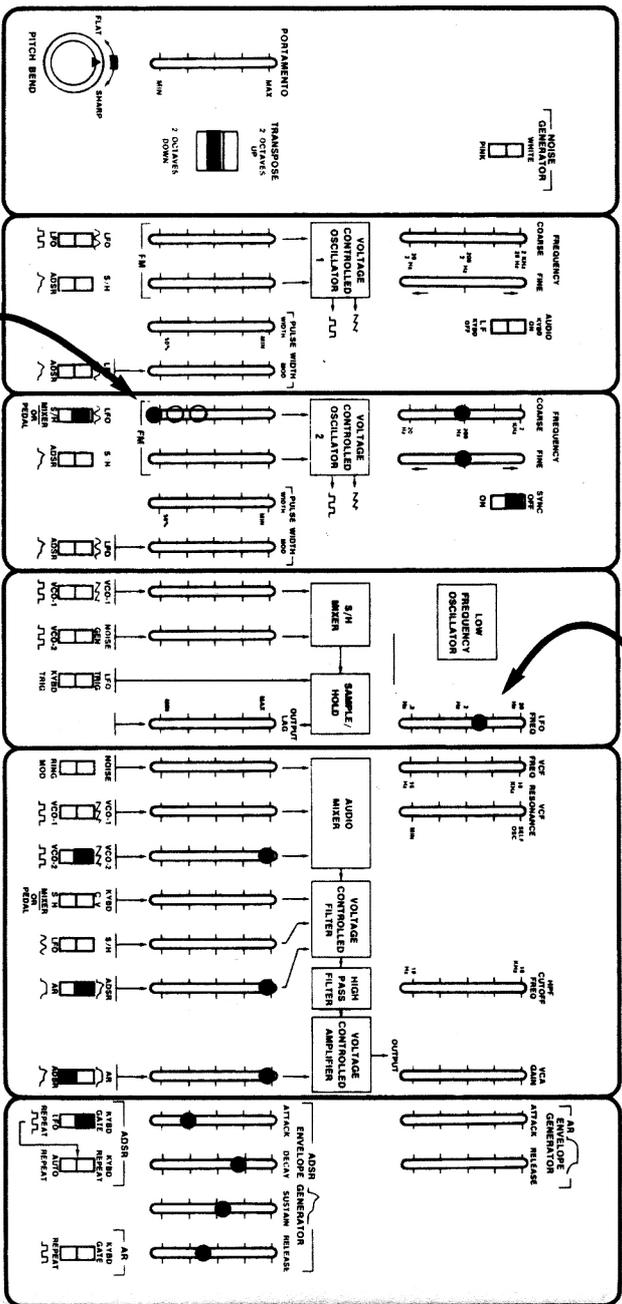

OPTIONAL VIBRATO

Single voice

4. Trumpet

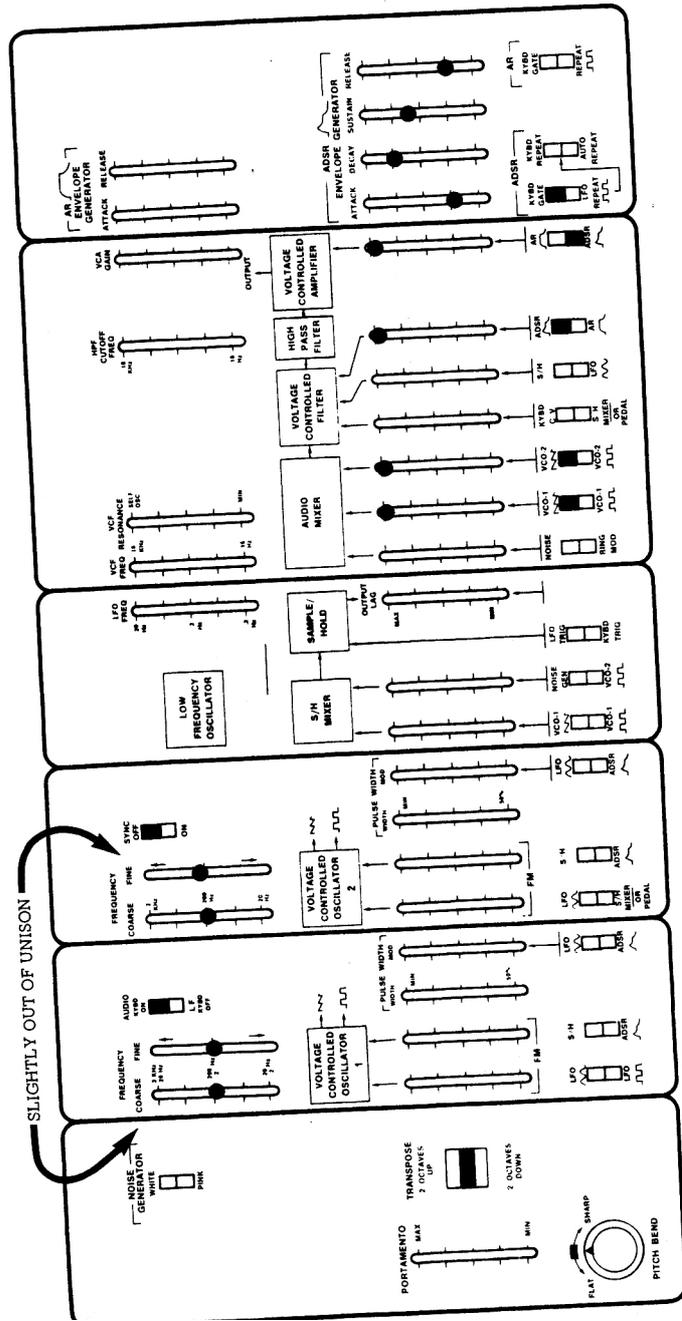

Two voice

5. Trumpet Chorus

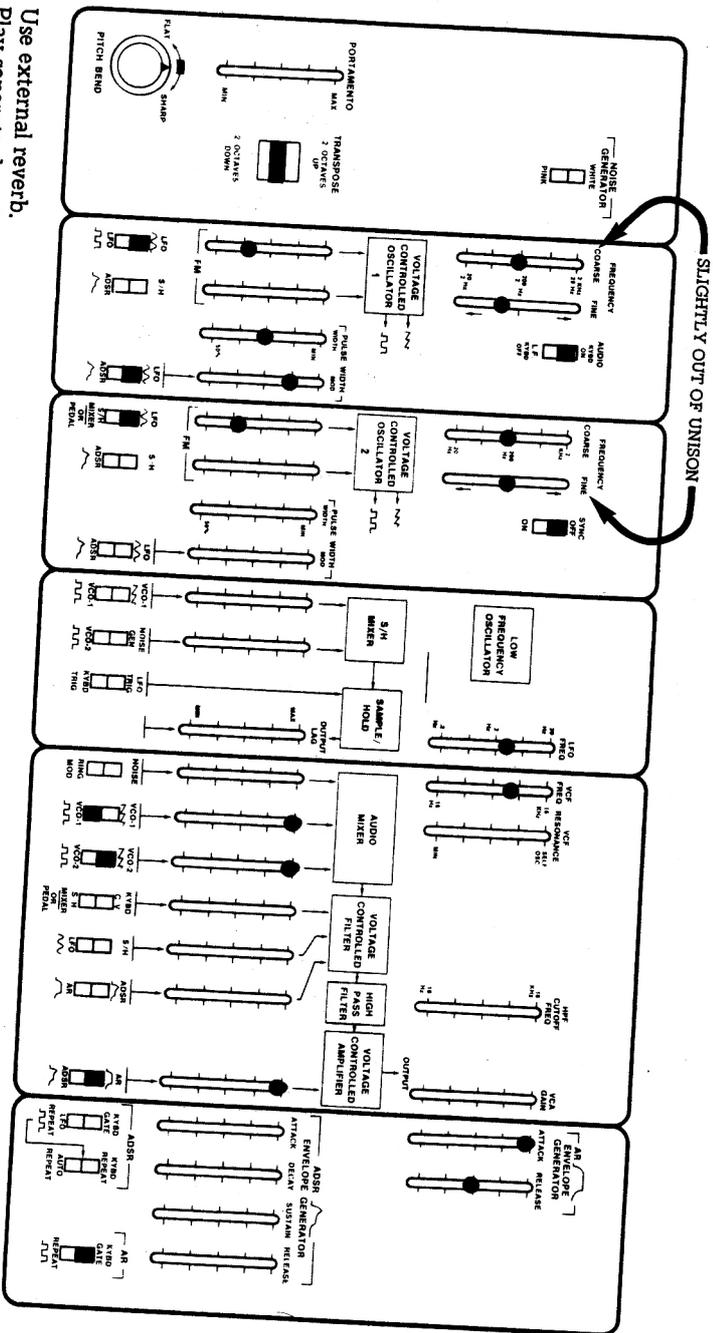

SLIGHTLY OUT OF UNISON

Use external reverb.
Play separate detached notes.

6. String Chorus

8. Electric Bass

Use PITCH BEND to "bend" notes.

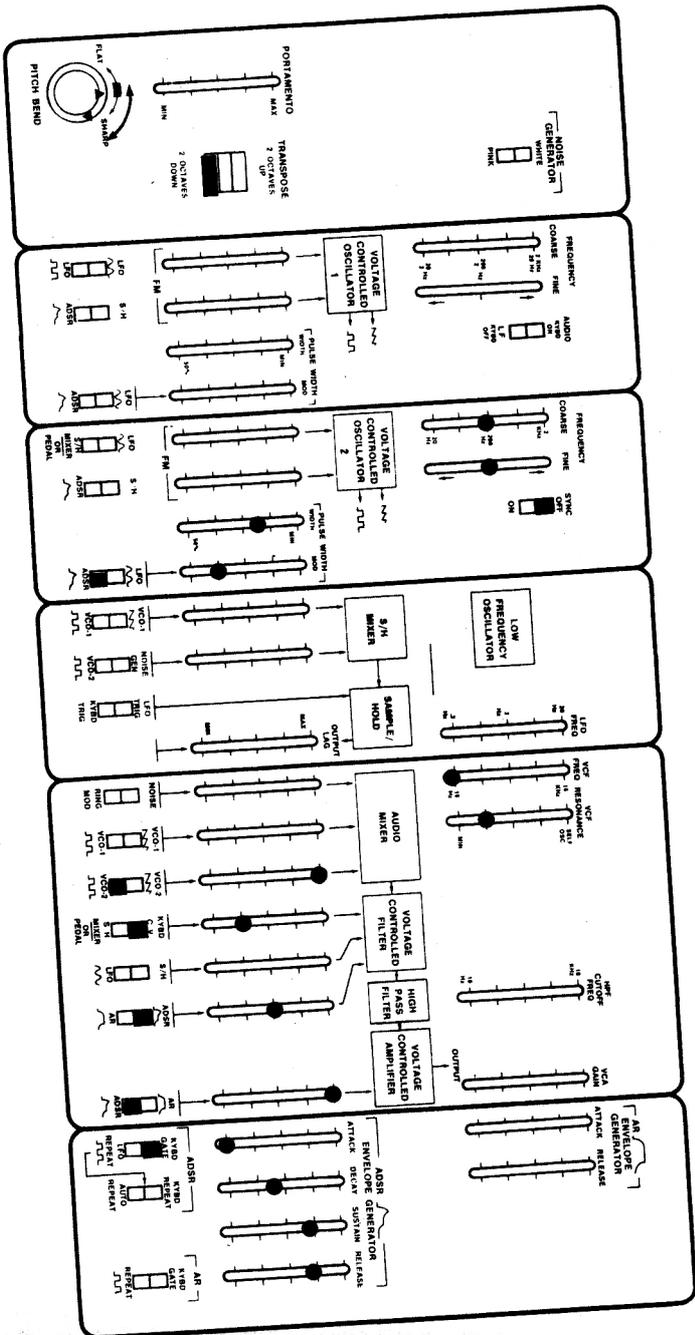

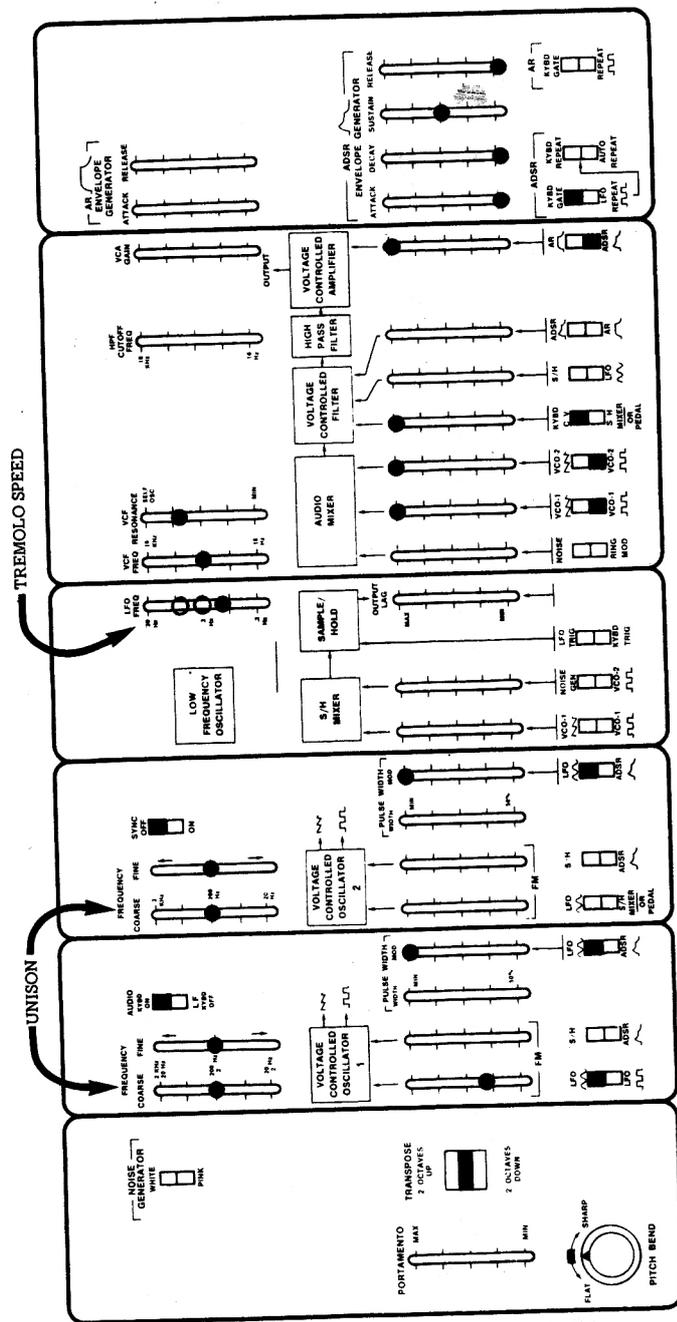

Set VCF RESONANCE at self-oscillating point;
tune VCF FREQUENCY to a fifth above the VCOs.

9. Screamo Organo

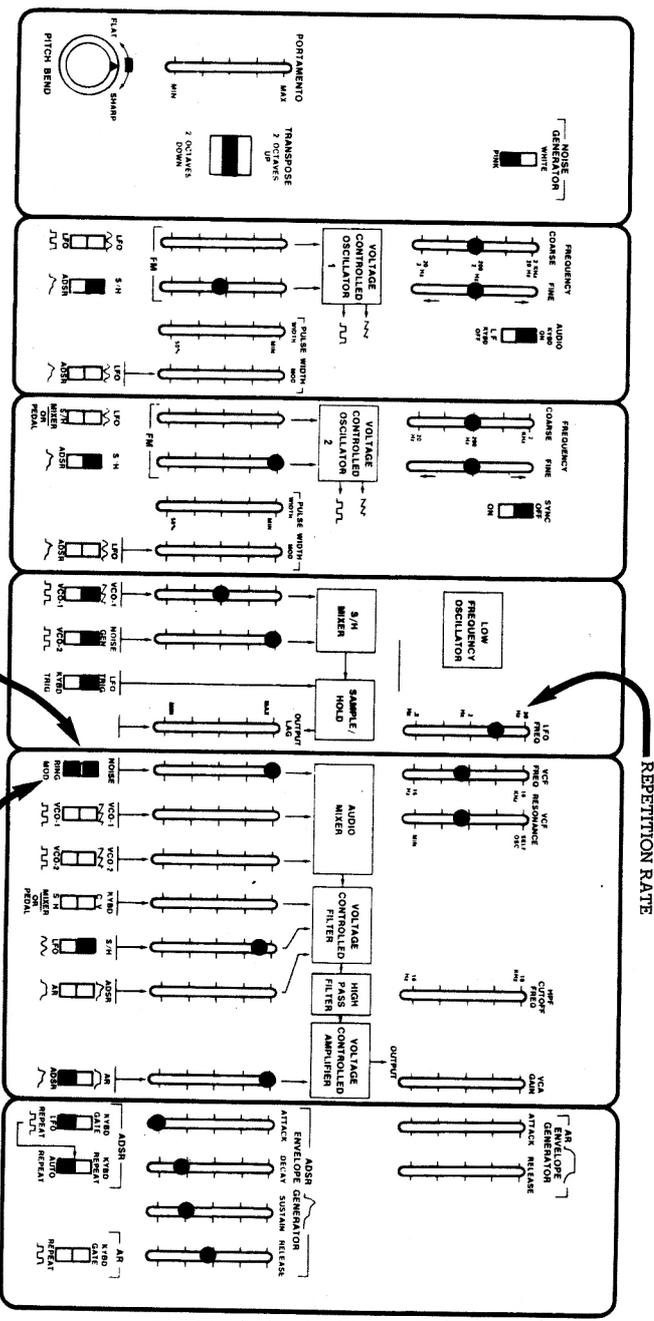

NOTE: Keyboard will "tune" metallic sounds and add off-beat accents.

10. Sample & Hold Percussion

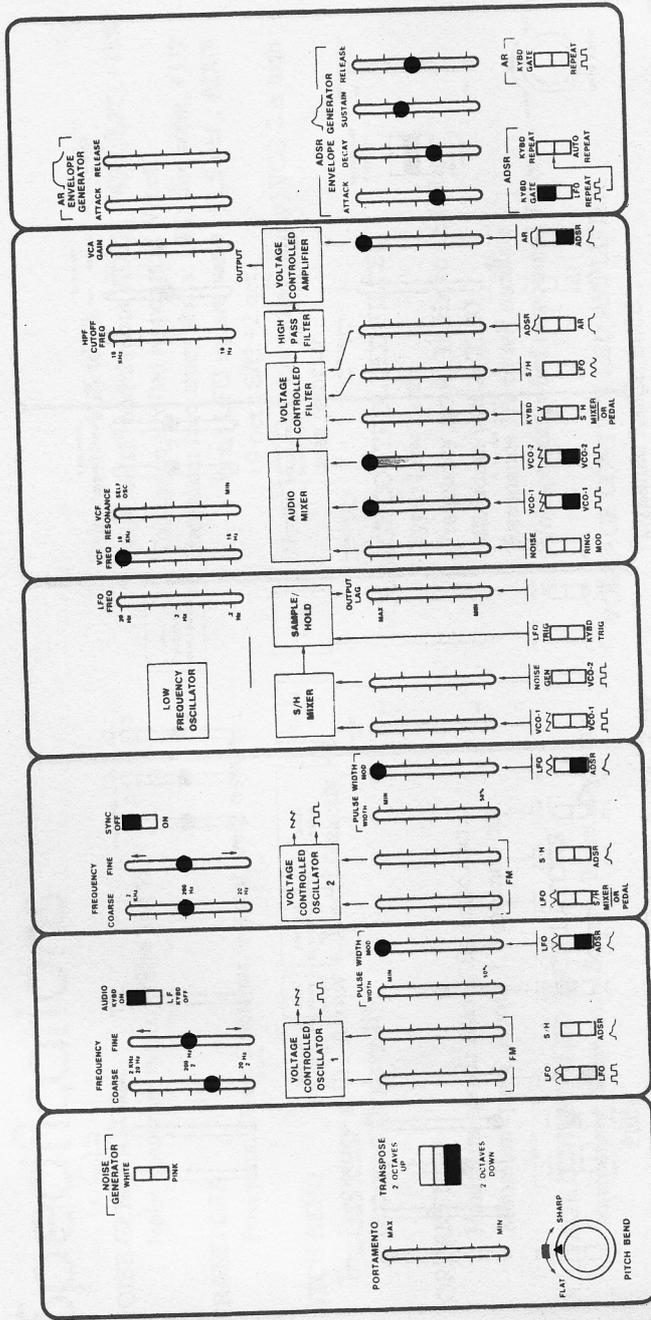

Tune VCO 1 one octave lower than VCO 2.

11. Heavy Led

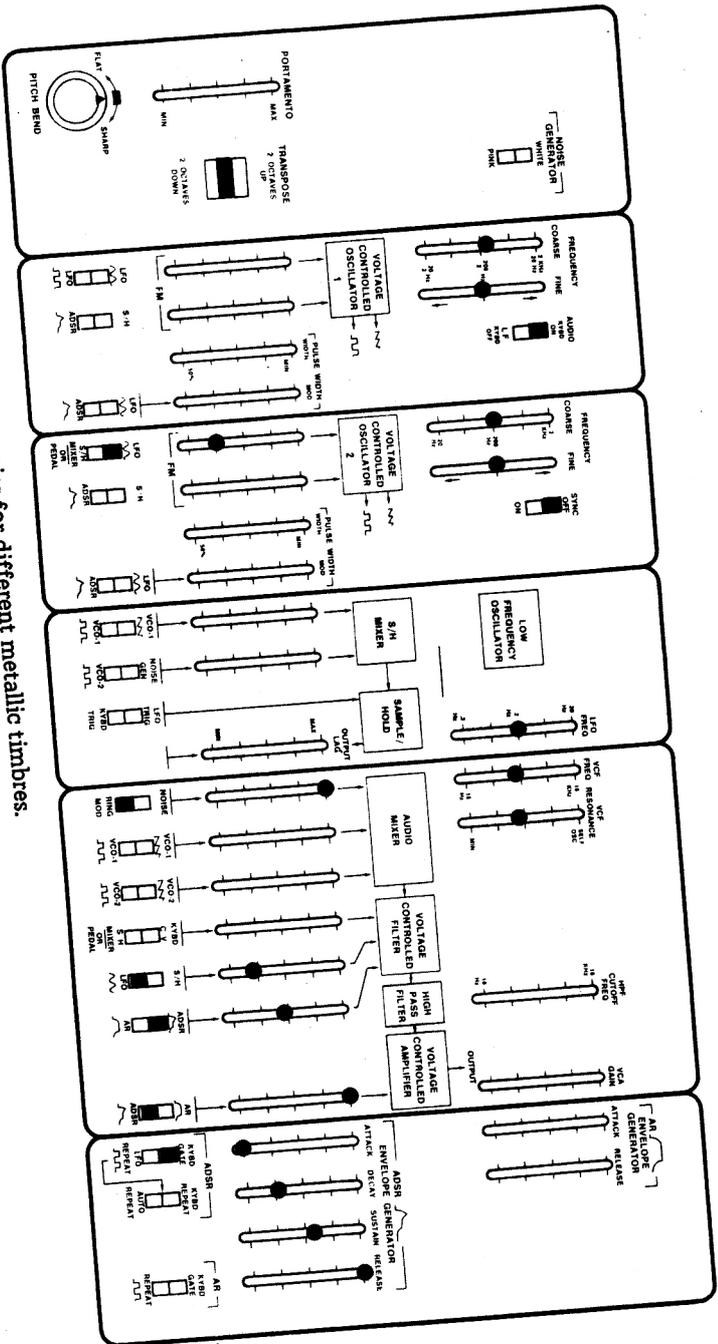

Tune VCOs 1 & 2 to different frequencies for different metallic timbres.

12. Gong/Chime

NOTE: All sliders not illustrated should be all the way down.
 Switches not illustrated do not affect the sound output in either position.

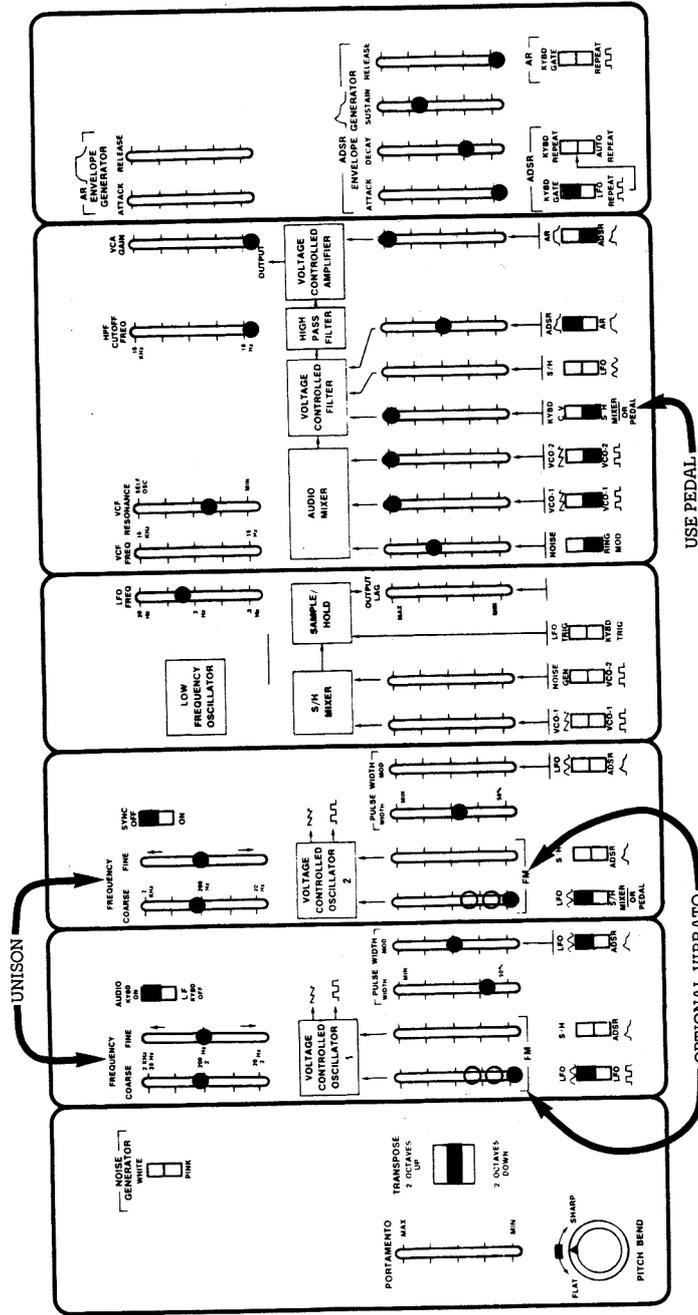

Tune VCO 1
 and VCO 2 to unison by
 holding down any key.

1. 2-Voice with Pedal Filter Control